

# Imager *M-lite* 16M

Small, light weight CMOS camera with USB 3.0 interface



The **Imager *M-lite* 16M** is a high sensitivity, high resolution digital camera, equipped with the new generation CMOS sensors with excellent image quality and low readout noise. The camera delivers true 12 bit digital images and comes with USB 3.0 interface for distances up to 25 m. The resolution of 16 Megapixel at 22 Hz frame rate in combination with its small and lightweight design makes this camera ideal for flexible use in highly ambitious applications in scientific as well as industrial fields.

## General System Specifications

<b>Exposure time</b>	19 $\mu$ s - 10 s
<b>Digital output</b>	12, 10 and 8 bit
<b>Interface</b>	USB 3.0 cable to camera, 5 meter length
<b>Lens mount</b>	C-mount adapter to F-mount included
<b>Number of pixels</b>	5320 x 3032 pixels
<b>Pixel size</b>	2.74 x 2.74 $\mu$ m <sup>2</sup>
<b>Full well capacity</b>	9,600 e <sup>-</sup>
<b>Max. QE</b>	65.7% @ 500 nm
<b>Frame rate</b>	22 frames/s @ 12 bit using the recommended USB 3.0 interface card
<b>Noise</b>	1.8 e <sup>-</sup>
<b>Operating temperature</b>	0 – 40 °C
<b>Size of camera head (L x W x H)</b>	48.12 mm x 47 mm x 47.5 mm
<b>Weight</b>	204 g
<b>Power requirements</b>	3.4 W via USB 3.0 interface

**Requirements** DaVis Software / PC / timing unit / Windows 7 or 10 (64 bit)  
**or** StrainMaster DIC Software  
 StrainMaster Controller **or** Device Control Unit X  
 PC / Windows 7 or 10 (64 bit)

## Quantum efficiency

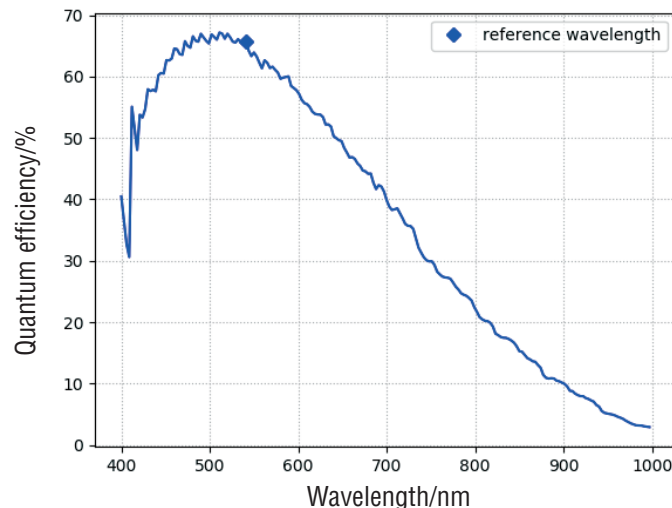

### LaVisionUK Ltd

2 Minton Place / Victoria Road  
 Bicester, Oxon / OX26 6QB / United Kingdom  
 E-mail: sales@lvision.com / www.lvisionuk.com  
 Phone: +44-(0)-870-997-6532 / Fax: +44-(0)-870-762-6252

### LaVision GmbH

Anna-Vandenhoeck-Ring 19  
 D-37081 Göttingen / Germany  
 E-mail: info@lvision.com / www.lvision.com  
 Tel. +49-(0)551-9004-0 / Fax +49-(0)551-9004-100

### LaVision Inc.

211 W. Michigan Ave. / Suite 100  
 Ypsilanti, MI 48197 / USA  
 E-mail: sales@lvisioninc.com / www.lvisioninc.com  
 Phone: (734) 485 - 0913 / Fax: (240) 465 - 4306

Dimensions

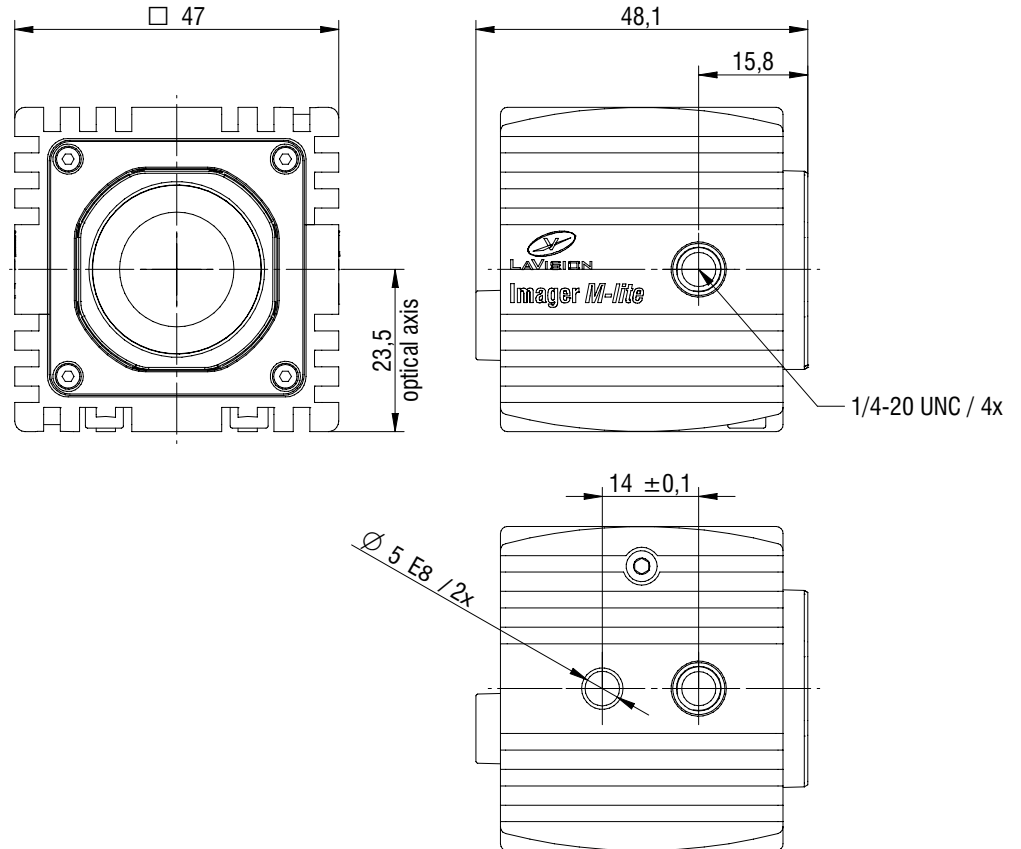

Ordering information

Part number	Description
1101515	Imager <i>M-lite</i> 16M camera
1009823	USB 3.0 interface card to connect up to 4 cameras
1012197	USB 3.0 extension cable 10 meter
1009887	USB 3.0 extension cable 20 meter

Data provided by LaVision are believed to be true. However, no responsibility is assumed for possible inaccuracies or omissions. All data are subject to change without notice.

Apr-21

**LaVisionUK Ltd**

2 Minton Place / Victoria Road  
Bicester, Oxon / OX26 6QB / United Kingdom  
E-mail: [sales@lavisoin.com](mailto:sales@lavisoin.com) / [www.lavisoinuk.com](http://www.lavisoinuk.com)  
Phone: +44-(0)-870-997-6532 / Fax: +44-(0)-870-762-6252

**LaVision GmbH**

Anna-Vandenhoeck-Ring 19  
D-37081 Göttingen / Germany  
E-mail: [info@lavisoin.com](mailto:info@lavisoin.com) / [www.lavisoin.com](http://www.lavisoin.com)  
Tel. +49-(0)551-9004-0 / Fax +49-(0)551-9004-100

**LaVision Inc.**

211 W. Michigan Ave. / Suite 100  
Ypsilanti, MI 48197 / USA  
E-mail: [sales@lavisoininc.com](mailto:sales@lavisoininc.com) / [www.lavisoininc.com](http://www.lavisoininc.com)  
Phone: (734) 485 - 0913 / Fax: (240) 465 - 4306